

CM SMART

Installation and Operating Instructions



CONTENTS

1. CM PUMP

1.1	General Data	3
1.2	Installation	3
1.3	Electrical Connections	4
1.4	Start Up	4
1.5	Operation and Maintenance	5

2. PRESS CONTROL

2.1	Applications	6
2.2	Technical Data	6
2.3	Mode of Operation	6
2.4	Installation	6
2.5	Electrical Connection	6
2.6	Starting and Maintenance	6 - 8

3. FAULT FINDING CHART

9 - 13

4. INSTALLATION

14 - 15

CM Pump

1.1 GENERAL DATA

APPLICATIONS:

Grundfos CM SMART Water Pressure Systems are suitable for a wide range of applications, including:

- Domestic Water Supply and Pressure Boosting.
- Domestic Irrigation.
- Washdown.

TYPE DESIGNATION:

The pumps used in the Pressure System are standard CM3 and CM5 Multistage pumps.

OPERATING RANGE:

Liquid temperature 0°C to 40°C
Maximum pump operating pressure 10bar(145psi).

1.2 INSTALLATION

PUMP LOCATION:

The pump should be housed in a weatherproof, ventilated enclosure. Care should be taken to ensure that an adequate air supply reaches the motor cooling fan.

PIPEWORK:

Suction and delivery pipes should be selected to withstand the maximum operating pressure of the system. Selection of pipe size should be carried out in consultation with a GRUNDFOS Dealer to ensure minimal friction losses. Unnecessary long suction lines should be avoided as should high spots in the suction line which may trap air.

A footvalve or non return valve should be installed on the suction side of the pump to prevent pressure loss through the suction line.

It is recommended that an isolating valve be fitted on the discharge side of the delivery manifold.

1.3 ELECTRICAL CONNECTIONS

Please ensure that the motor is suitable for the electrical supply on which it is to be used. All single phase Water Pressure System are supplied with a lead cable for ease of installation.

Three phase motors should be connected to the supply as shown in the terminal box cover.

MOTOR PROTECTION:

SINGLE PHASE MOTORS

GRUNDFOS Standard motors have built-in thermal relays and require no further motor protection.

THREE PHASE MOTORS

These motors must be connected to an effective motor starter to ensure that the motor is protected against damage from phase failure, voltage variations and overload. The overload unit should be adjusted to trip at the motor full load current shown on the motor nameplate.

1.4 START UP

PRIMING:

Do not attempt to start the pump until both the suction line and pump body have been completely filled with water. Care should be taken to ensure that no air remains entrapped in the suction line.

POSITIVE SUCTION

Gradually open the isolating valve in the suction pipe until a steady stream of water runs out the priming port. Replace the plug and tighten securely. Completely open the isolating valve.

NEGATIVE SUCTION

In an open system where the liquid level is below the pump, the suction pipe and the pump must be filled and vented of air before starting the pump. Close the discharge isolating valve. Pour water through the priming hole, until the suction pipe and the pump are completely filled with water.

CHECK THE DIRECTION OF ROTATION: (Three Phase Only)

Once the priming of the pump is completed, start the pump and observe the direction of rotation. If the pump is rotating in the opposite direction to the arrows shown on the pump head and fan cowl, isolate the power supply and make the following change.

THREE PHASE: Change over any two of the three supply lines in the motor terminal box.

1.5 OPERATION AND MAINTENANCE

LUBRICATION AND MAINTENANCE:

Pumps installed in accordance with these instructions will operate efficiently with very little maintenance. The mechanical shaft seal is self adjusting and has wear-resistant seal faces which are lubricated and cooled by the pumped liquid. Pump bearing are also lubricated by the pumped liquid. All GRUNDFOS motors have sealed bearings and do not require routine lubrication.

INSPECTION:

At regular intervals, depending on the conditions of service and hours of operation, the following checks should be carried out.

- Pump performance and operating pressure.
- Check for any gasket, shaft seal or pipeline leaks.
- Check for any motor bearing wear.
- Remove and clean any filters.
- Operation of all controls.
- Frequency of starts and stops.

PRESSURE TANK PRE-CHARGE:

The Pressure tank pre-charge is pre-set. On site adjustment should be made with power off and delivery line open so that there is no pressure on the system. The pressure tank pre-charge should be 10% below cut in pressure.

Pressure Manager



Before beginning installation procedures, these Installation and Operating Instruction should be studied carefully. The installation and operation should also be in accordance with local regulations and accepted codes of good practice.

2.1 APPLICATIONS

The Pressure Manager is a pressure regulator with built-in dry-running protection designed for use with GRUNDFOS pumps. It is used for automatic operation of pumps in small water supply systems in single-family houses and blocks of flats, for garden watering, etc.

2.2 TECHNICAL DATA

Ambient temperature

Max. +50°C

Liquid temperature

Max. +40°C

Cut-in pressure

1.5 bar

System pressure

Max. 10 bar

Supply voltage

1 x 220-240 V, 50 Hz

Enclosure class

IP 65

Dimensions

See **Fig. J** at the end of these instructions

The technical data may be limited by the pump data. See Installation and Operating Instructions for the pump.

2.3 MODE OF OPERATION

By means of a built-in flow valve and a pressure switch, the Pressure Manager ensures a steady flow without water hammering, irrespective of the water consumption.

The Pressure Manager start and stops the pump automatically on demand.

The pump will start at the preset cut-in pressure. The Pump will stop when water is no longer being drawn off.

The Pressure Manager incorporates a pump dry-running protection, which will stop the pump if it has been running for approx. 10 seconds without delivering water.

2.4 INSTALLATION

The Pressure Manager must be fitted on the discharge side of the pump.

See installation example on page 14 & 15 at the end of these instructions.

When pumping from a well, borehole, etc., a non-return valve must always be fitted to the suction pipe of the pump.

It is recommended to connect the pump/ Pressure Manager to the piping system by means of unions.

2.5 ELECTRICAL CONNECTION

The electrical connection and protection should be carried out in accordance with local regulations.



Never make any connections in the terminal box of the Pressure Manager unless the electricity supply has been switched off.

Connections should be made as shown in Fig. K at the end of these instructions.

2.6 STARTING AND MAINTENANCE

Fig L shows the control panel on the Pressure Manager

Fig L

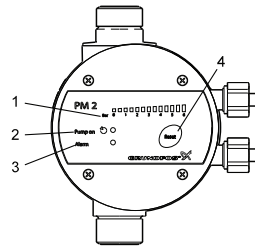

TM03 9361 1508

Control panel

Pos.	Description	Function
1	"Pressure scale"	The pressure scale has 13 light fields indicating the pressure from 0 to 6 bar. All light fields illuminate briefly when the power supply is switched on.
2	"Pump on"	The green indicator light is permanently on when the pump is running. The indicator light also illuminates briefly when the power supply is switched on.
3	"Alarm"	The red indicator light is permanently on or flashes when the pump has stopped due to an operating fault. The indicator light also illuminates briefly when the power supply is switched on.
4	[Reset]	The button is used for <ul style="list-style-type: none"> • resetting of fault indications • checking of DIP switch settings.

When the Pressure Manager has been installed and the electrical connection has been carried out, switch on the electricity supply.

Pressure Manager

The green indicator light (Supply) illuminates. The pump will start when the electricity supply or a possible on/off switch on the delivering water within 10 seconds, the dry-running protection will stop the pump.

To avoid this, press the Reset button until the pump starts delivering water (the pump has been primed).

Note : The pump is not allowed to run without delivering water for a period longer than that stated in the Installation and Operating Instructions for the pumps.

Functions

Auto-reset

When the auto-reset function is enabled, cycling and dry-running alarms will be automatically reset. To enable the function, set DIP switch 6 to "ON".

Caution *The auto-reset function should NOT be enabled on pumps which cannot self-prime when water returns after dry-running.*

Anti-cycling

To avoid inadvertent starts and stops of the pump in case of a failure in the installation, the anti-cycling function can be enabled. The function will detect cycling if it occurs and stop the pump with an alarm. When the PM 2 has been set to start/stop according to water consumption, cycling may occur in the following situations:

- In case of a minor leakage.
- If a tap has not been entirely closed.

When the PM 2 has been set to start/stop with 1 bar differential pressure, cycling may occur in the following situations:

- If the pressure tank has lost its precharge pressure.
- If the size of the pressure tank is insufficient.

If the cycling alarm has been activated, the pump can be restarted manually by pressing [Reset]. When the auto-reset function is enabled, the pump will be restarted automatically after 12 hours in alarm condition. To enable the function, set DIP switch 7 to "ON".

Note *In case of a very small consumption, the anti-cycling function may register this as a minor leakage and stop the pump inadvertently. If this occurs, the function can be disabled.*

Maximum continuous operating time (30minutes)

When this function is enabled, the pump will be stopped when the pump has been running continuously for 30 minutes.

Restart the pump by pressing [Reset].

The purpose of this function is to avoid unnecessary water and current consumption, e.g. in case of pipe Tfracture or considerable leakages.

Note *When the function is enabled, any consumption exceeding 30 minutes will cause an alarm, and the pump will be stopped. If enabled, the auto-reset function will not restart the pump.*

To enable the function, set DIP switch 8 to "ON".

Fig K

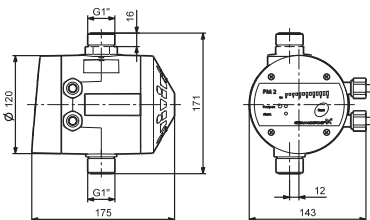

TM04 1991 1708

Fig J

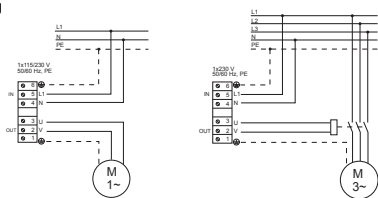

TM03 9 220 3707 - TM04 1953 1508

Pressure Manager

DIP switches

The PM 2 has a number of settings which can be made with the DIP switch behind the control panel. See fig. 6.

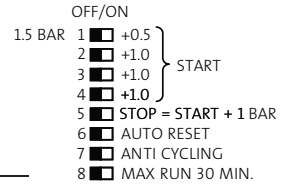

Fig. 6 DIP switches

DIP switch		Description	Default setting
No.	Name		
1-4	START	Start pressure (p_{start}) With these DIP switches the start pressure can be set from 1.5 to 5.0 bar in steps of 0.5 bar. Example: DIP switch 1 = "ON" DIP switch 2 = "ON" Start pressure = 1.5 + 0.5 + 1 = 3 bar See section 7.2.1 Starting and stopping conditions.	All set to OFF (p _{start} = 1.5 bar)
5	STOP = START + 1 BAR	Start/stop with 1 bar differential pressure (This operating mode is only suitable for systems with a pressure tank). When the DIP switch has been set to "ON", the pump stop pressure will be equal to p _{start} + 1 bar. See section 7.2 Start/stop with 1 bar differential pressure. In systems without a pressure tank, the DIP switch must be set to "OFF".	OFF (start/stop according to water consumption)
6	AUTO RESET	Automatic resetting of alarms When the DIP switch has been set to "ON", the cycling and dry-running alarms will automatically be reset if they have been activated. See section 8.1 Auto-reset.	OFF (manual resetting)
7	ANTI CYCLING	Anti-cycling When the DIP switch has been set to "ON", the pump will be stopped in case of cycling. See section 8.2 Anti-cycling.	OFF
8	MAX RUN 30 MIN.	Maximum continuous operating time (30 minutes) When the DIP switch has been set to "ON", the pump will automatically be stopped if it has been running continuously for 30 minutes. See section 8.3 Maximum continuous operating time (30 minutes).	OFF

Enabling the DIP switch settings

Note When the desired DIP switch settings have been made, they must be enabled, otherwise the PM 2 cannot detect the settings.

To enable the DIP switch settings, press [Reset] or disconnect and reconnect the power supply to the unit.

Checking the DIP switch settings

When [Reset] is kept pressed for at least 3 seconds, the light fields for the DIP switches set to "ON" will illuminate in the pressure scale. The light fields illuminate from right to left. This means that if the light field to the far right is on, DIP switch 8 has been set to "ON", etc. See the table below.

Light field [bar]	2.5	3.0	3.5	4.0	4.5	5.0	5.5	6.0
DIP switch no.	1	2	3	4	5	6	7	8

Fault Finding Chart



Warning

Before starting work on the pump, make sure that the power supply to the pump has been switched off and that it cannot be accidentally switched on.

Fault	Checks (Possible causes)	Remedy
1. The pump does not run.	a) Supply failure.	Switch on the switch. Check cables and cable connections for defects and loose connections.
	b) Fuses are blown.	Check cables and cable connection for defects, and replace the fuses.
	c) Motor protection tripped.	See 2. a), b), c), d), e), f).
	d) Control-current circuit defective.	Repair or replace the control-current circuit.
2. Motor-protective circuit breaker has tripped (trips out immediately when supply is switched on).	a) Fuses are blown	See 1. b).
	b) Contacts of the motor-protective circuit breaker or magnet coil defective.	Replace the contacts of the motor-protective circuit breaker, the magnet coil or the entire motor-protective circuit breaker.
	c) Cable connection is loose or faulty.	Check cables and cable connections for defects, and replace the fuses.
	d) Motor winding is defective.	Repair or replace the motor.
	e) The pump is mechanically blocked.	Switch off the power supply, and clean or repair the pump.
	f) The setting of the motor-protective circuit breaker is too low.	Set the motor-protective circuit breaker according to the rated current of the motor (I ₁ /1). See nameplate.
3. The motor-protective circuit breaker trips out occasionally.	a) The setting of the motor-protective circuit breaker is too low.	See 2.f).
	b) Periodic supply failure.	See 2.c).
	c) Periodically low voltage.	Check cables and cable connections for defects and loose connections. Check that the supply cable of the pump is correctly sized.

Fault Finding Chart

Fault	Checks (Possible causes)	Remedy
4. The pump performance is unstable.	a) Pump inlet pressure too low.	Check the inlet conditions of the pump.
	b) Suction pipe is partly blocked by impurities.	Remove and clean the suction pipe.
	c) Leakage in suction pipe.	Remove and repair the suction pipe.
	d) Air in suction pipe or pump.	Vent the suction pipe/pump. Check the inlet conditions of the pump.
5. The pump runs, but gives no water.	a) Pump inlet pressure too low.	See 5. a).
	b) The suction pipe is partly clogged by impurities.	See 5. b).
	c) The foot or non-return valve is stuck in its closed position.	Remove and clean, repair or replace the valve.
	d) Leakage in suction pipe.	See 5. c).
	e) Air in suction pipe or pump.	See 5. d).
6. The pump runs backwards when switched off.	a) Leakage in suction pipe.	See 5. c).
	b) Foot or non-return valve defective.	See 6. c).
	c) The foot valve is stuck in completely or partly open position.	See 6. c).
7. The pump runs with reduced performance.	a) Wrong direction of rotation.	Three-phase pumps only: Switch off the power supply with the external circuit breaker, and interchange two phases in the pump terminal box. See also section 8.2 Checking the direction of rotation.
	b) See 5. a), b), c), d).	
8. The green light field for "0 bar" is off even if the power supply has been switched on.	a) The fuses in the electric installation have blown.	Replace the fuses. If the new fuses also blow, check the electric installation.
	b) The earth leakage circuit breaker or the voltage-operated circuit breaker has been tripped out.	Cut in the circuit breaker.
	c) No power supply.	Contact the power supply authorities.
	d) The PM unit is defective.	Repair or replace the PM unit.

Fault Finding Chart

Fault	Checks (Possible causes)	Remedy
8. The green light field for "0 bar" is off even if the power supply has been switched on.	a) The fuses in the electric installation have blown.	Replace the fuses. If the new fuses also blow, check the electric installation.
	b) The earth leakage circuit breaker or the voltage-operated circuit breaker has been tripped out.	Cut in the circuit breaker.
	c) No power supply.	Contact the power supply authorities.
	d) The PM unit is defective.	Repair or replace the PM unit.
9. The green "Pump on" indicator light is on, but the pump does not start.	a) The power supply to the pump is disconnected after the PM unit.	Check the plug and cable connections, and check if the built-in circuit breaker of the pump is switched off.
	b) The motor protection of the pump has tripped out due to overload.	Check if the motor/pump is blocked.
	c) The pump is defective.	Repair or replace the pump.
	d) The PM unit is defective.	Repair or replace the PM unit.
10. The pump does not start when water is consumed. "Pump on" is off.	a) Too big difference in height between the PM unit and the tapping point.	Adjust the installation, or increase the start pressure.
	b) The PM unit is defective.	Repair or replace the PM unit.
11. System without pressure tank: Frequent starts/stops.	a) DIP switch 5 set to "ON".	Set DIP switch 5 to "OFF".
	b) Leakage in the pipework.	Check and repair the pipework.
	c) The non-return valve is stuck in open position.	Clean or replace the non-return valve.
12. System with pressure tank: Frequent starts/stops.	a) The pressure tank has no precharge pressure, or the tank size is insufficient.	Check the tank precharge pressure, and recharge the tank, if necessary. If the size of the pressure tank is insufficient, set DIP switch 5 to "OFF", or replace the pressure tank.
	b) Leaky non-return valve.	Clean or replace the non-return valve.

Fault Finding Chart

Fault	Checks (Possible causes)	Remedy
13. The pump does not stop.	a) The pump cannot deliver the necessary discharge pressure.	Replace the pump.
	b) The start pressure is set too high.	Decrease the start pressure.
	c) The PM unit is defective.	Repair or replace the PM unit.
	d) The non-return valve is stuck in open position.	Clean or replace the non-return valve.
14. The red "Alarm" indicator light is permanently on.	a) Dry running. The pump needs water.	Check the pipework.
	b) The power supply to the pump is disconnected after the PM unit.	Check the plug and cable connections, and check if the built-in circuit breaker of the pump is switched off.
	c) The motor protection of the pump has tripped out due to overload.	Check if the motor/pump is blocked.
	d) The pump is defective.	Repair or replace the pump.
	e) The PM unit is defective.	Repair or replace the PM unit.
15. System without pressure tank: The red "Alarm" indicator light flashes once per period.	a) Cycling. A tap has not been closed entirely after use.	Check that all taps have been closed. See section 8.2 Anti-cycling.
	b) Cycling. There is a minor leakage in the system.	Check the system for leakages. See section 8.2 Anti-cycling.
16. System with pressure tank: The red "Alarm" indicator light flashes once per period.	a) Cycling. The pressure tank has no precharge pressure, or the tank size is insufficient.	Check the tank precharge pressure, and recharge the tank, if necessary. If the size of the pressure tank is insufficient, set DIP switch 5 to "OFF", or replace the pressure tank. See section 8.2 Anti-cycling.

Fault Finding Chart

Fault	Checks (Possible causes)	Remedy
17. The red "Alarm" indicator light flashes twice per period.	a) Maximum continuous operating time (30minutes). The pump has been running continuously for 30minutes.	Check the system for leakages. Disable the function to allow the pump to run for 30 minutes. See section 8.3 Maximum continuous operating time (30minutes).
18. The red "Alarm" indicator light flashes three times per period, and each pump start is delayed a few seconds.	a) Too many start/stop sequences within a short period. The pressure tank has no precharge pressure, or the tank size is insufficient.	Check the tank precharge pressure, and recharge the tank, if necessary. If the size of the pressure tank is insufficient, set DIP switch 5 to "OFF", or replace the pressure tank. Set DIP switch 5 to "OFF".
	b) Too many start/stop sequences within a short period. The PM 2 is set to start stop with 1 bar differential pressure, i.e. DIP switch 5 is set to "ON", but no pressure tank has been installed in the system.	
19. The red "Alarm" indicator light flashes four times per period.	a) Pressure sensor fault. Repair or replace the PM unit.	

Installation 1

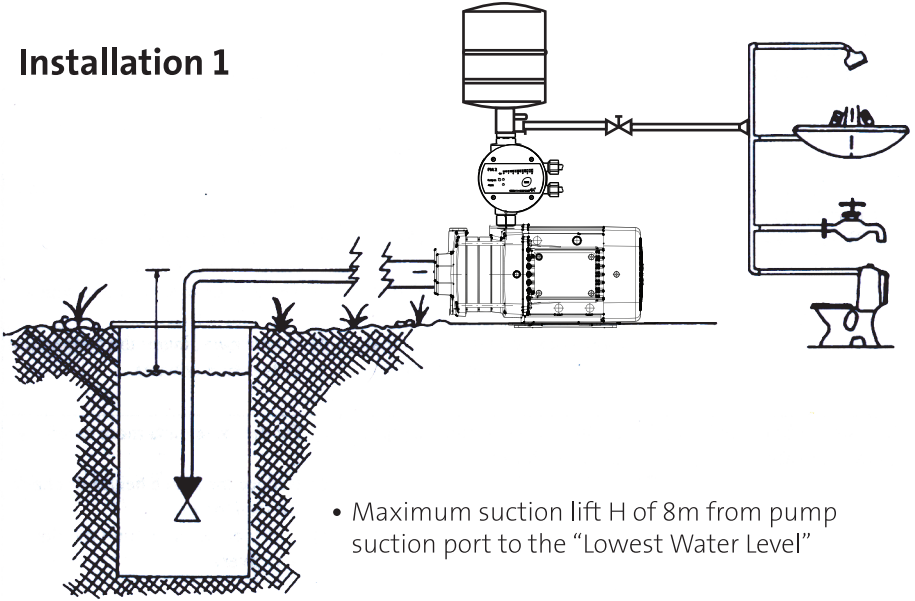

- Maximum suction lift H of 8m from pump suction port to the "Lowest Water Level"

Installation 2

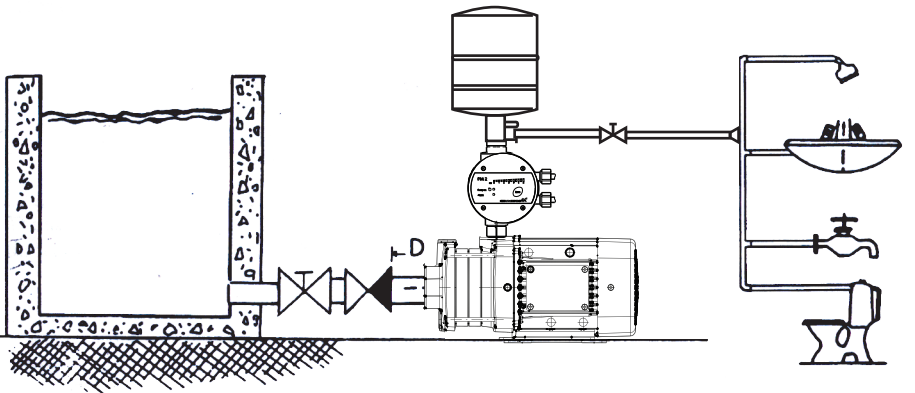

- Check valve at Suction side must be with a minimum distance of 4 x diameter of inlet pipe from the suction port

Installation 3

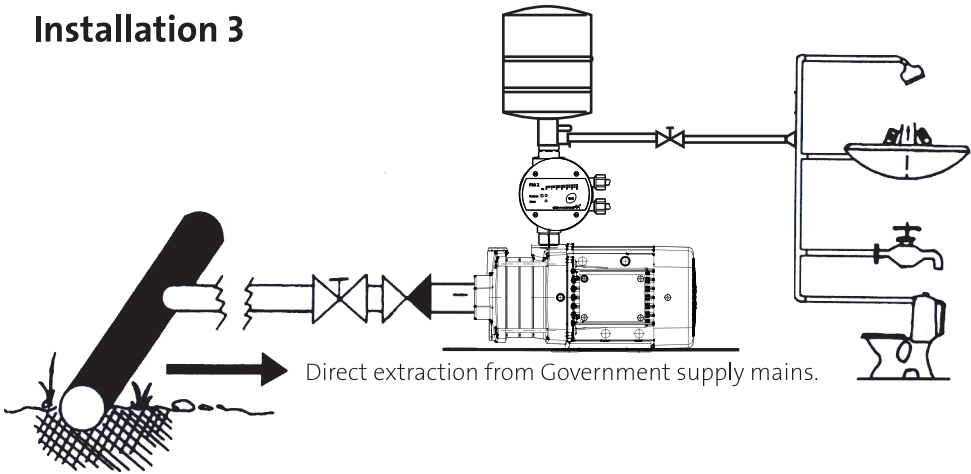

- Direct extraction from Government supply mains usually against regulation, therefore we recommend installation of suction tank as per installation 2

Points to note:

- Do not attempt to start the pump until both suction line and pump have been completely filled with water.
- Suction pipe to be as short as possible.
- Minimum pipe size to be the same as pump's inlet.
- Shelter is required for outdoor installation.

Overall Diagram

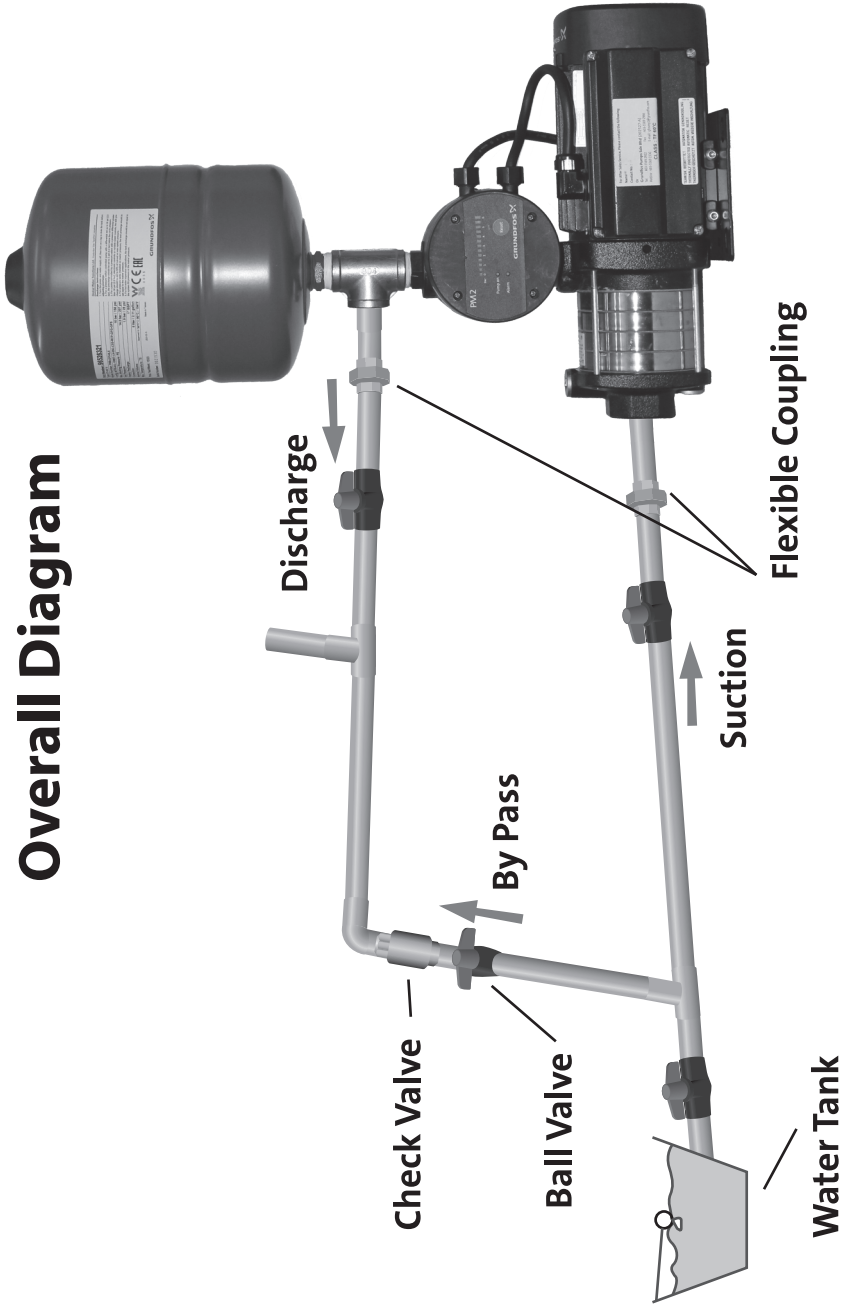

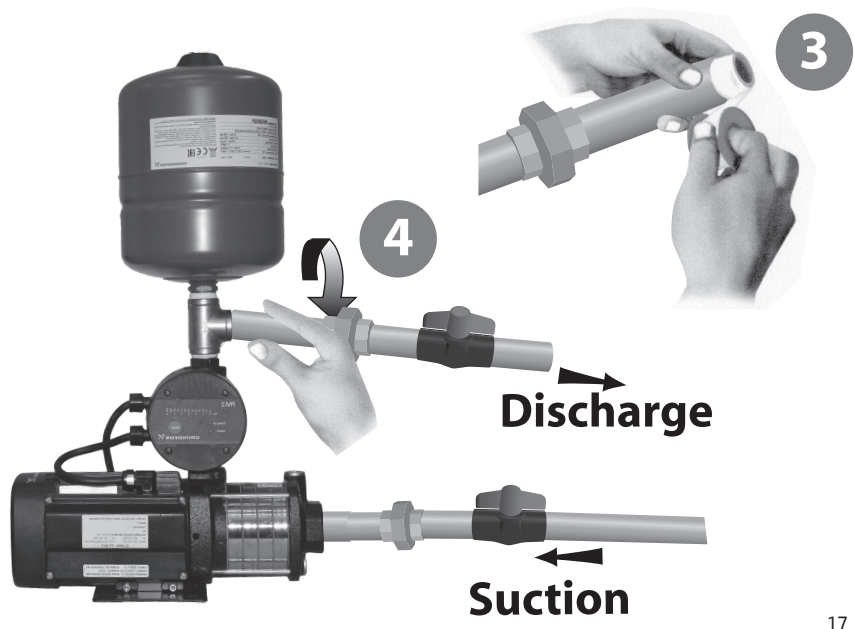
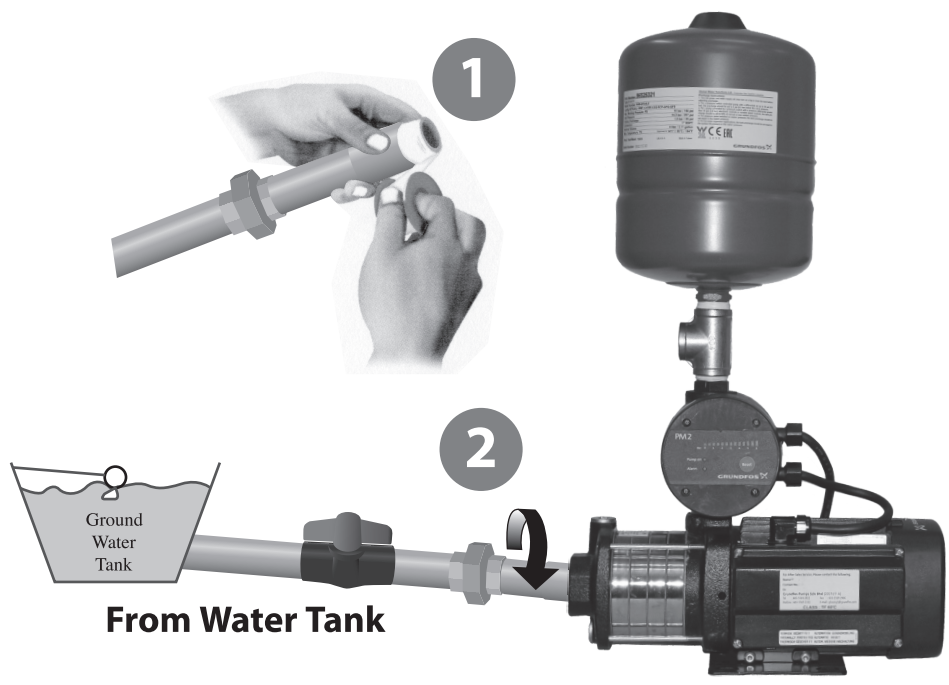

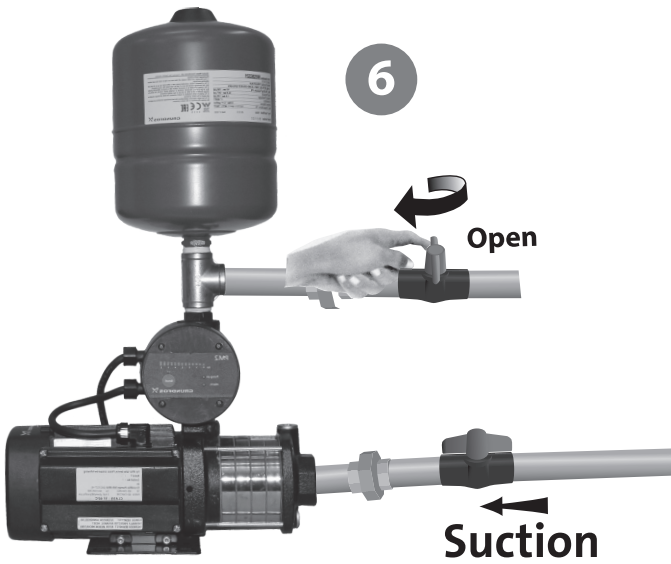
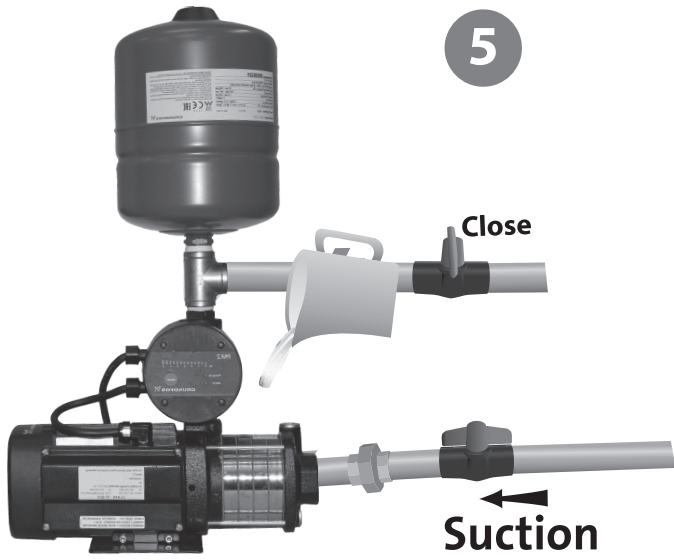

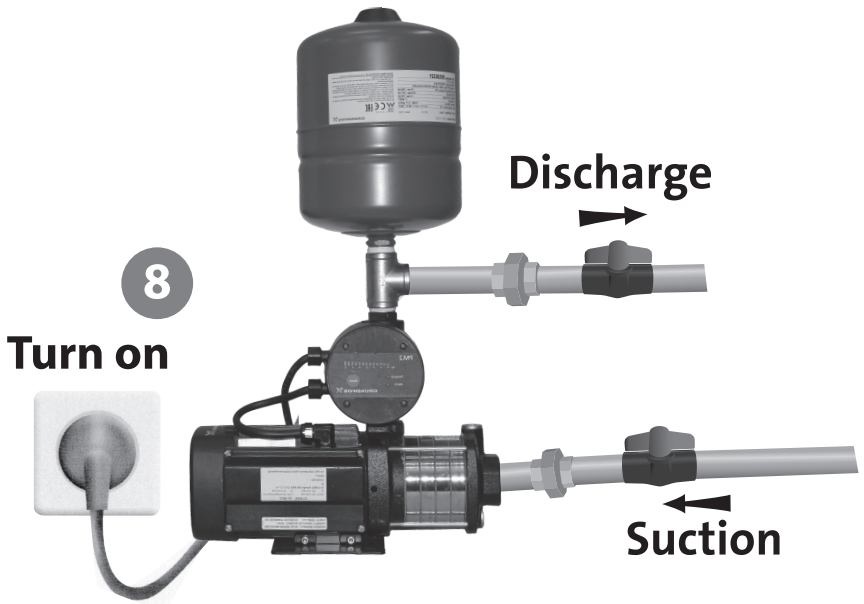
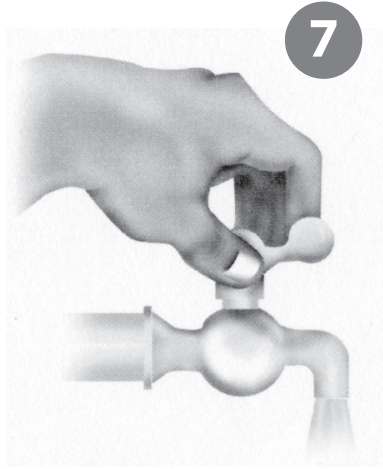

PROPER WAY TO INSTALL GRUNDFOS DOMESTIC WATER PUMP

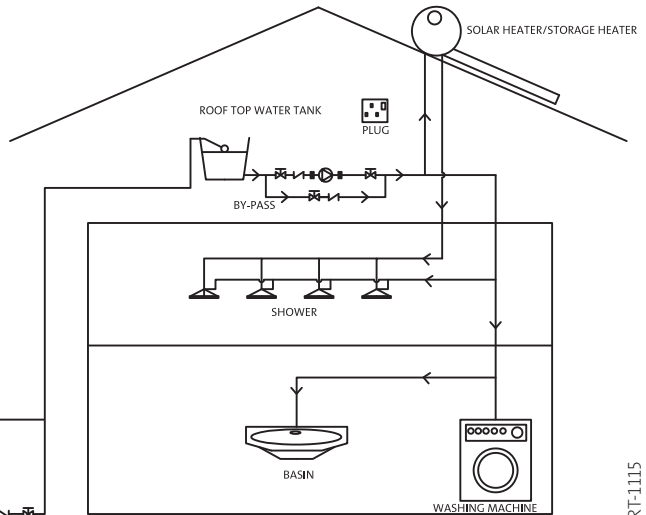
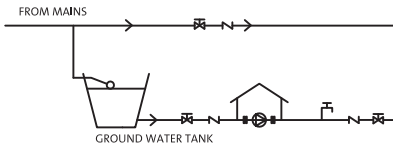
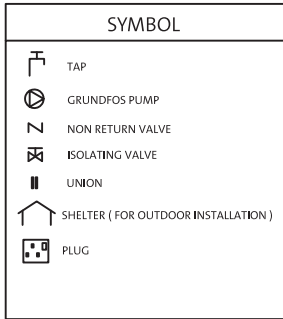

- * We reserve the right to decline warranty claim if the above installation is not followed.
- * Direct suction from main is prohibited.

Subject to alterations. CM SMART-1115

GRUNDFOS PUMPS SDN BHD (202527-A)

7, Jalan Peguam U1/25
Glenmarie Industrial Park
40150 Shah Alam, Selangor,
Malaysia.

Tel : +603-5569 2922
Fax : +603-5569 2866
E-mail: gfosmy1@grundfos.com
Website : www.grundfos.com

Toll Free No. : 1800 88 PUMP (7867)



Branch Offices
Northern
10, Ground Floor,
Jalan Todak 4, Bandar Sunway,
13700 Seberang Jaya,
Penang
Tel : +604-818 3779
Fax : +604-818 3848

East Malaysia
Lot 8, Lorong Industri Warisan 1,
Taman Industri Warisan Indah,
Mile 7, Old Tuaran Road
88450 Inanam, Kota Kinabalu,
Sabah
Tel : +6088-380 663/-383 663
Fax : +6088-383 621

